

**Joint ReSIST/EWICS TC7  
Workshop on Teaching Resilient Computing  
Erlangen, Germany – May 2nd, 2007**

## **Education and Training Issues in Electric Power Industry**

**Zdzislaw Zurakowski**  
Private Contractor  
e-mail: [zz@pvd.pl](mailto:zz@pvd.pl)

# Outline

---

- 1. Introduction**
- 2. What it is an Electric Power System (EPS)?**
- 3. Current situation in education curricula**
- 4. Proposal of information technology courses for Electrical Engineering Faculties**

## Introduction

---

**Towards the end of the XX century Electric Power Systems (EPSs) emerged as the most critical infrastructure that is also considered one of the most vulnerable to physical and cyber attack.**

**Contemporary EPSs are very complex and highly technologically advanced systems. The vast, highly interconnected North American EPS has been called the „greatest machine ever created”.**

**The nature of possible consequences for an EPS in case of some security breaches is unique, based on concepts that are normally not known in others sectors.**

## Introduction

---

**A quotation from a paper published in the journal of CIGRE (International Council on Large Electric Systems), one of the leading worldwide Organizations on Electric Power Systems:**

**“Concerns were raised also on the practice of outsourcing of Companies activities – finance, IT, logistics... as a result of pressure on costs. Managers at decision-making level are often external to power engineering circles. This will contribute to shattering any attractive image of the Industry”**

**(“CIGRE and Electric Power Education”, ELECTRA No. 223, December 2005, page 22)**

## **What it is an Electric Power System (EPS)?**

---

- **What is physical and organisational structure of an electric power infrastructure?**
- **What it is an electric power system (EPS) and why we are creating such a big and complex EPSs?**
- **What is the role of IT in an EPS and what is configuration of telecommunication network integrated with an EPS?**
- **How an EPS work and how it is operated, controlled and protected?**
- **EPS vulnerabilities and what can happen in case of security breaches?**
- **What is a blackout and how it can happen?**

# What is an Electric Power System (EPS)?

Approximate block diagram of an EPS

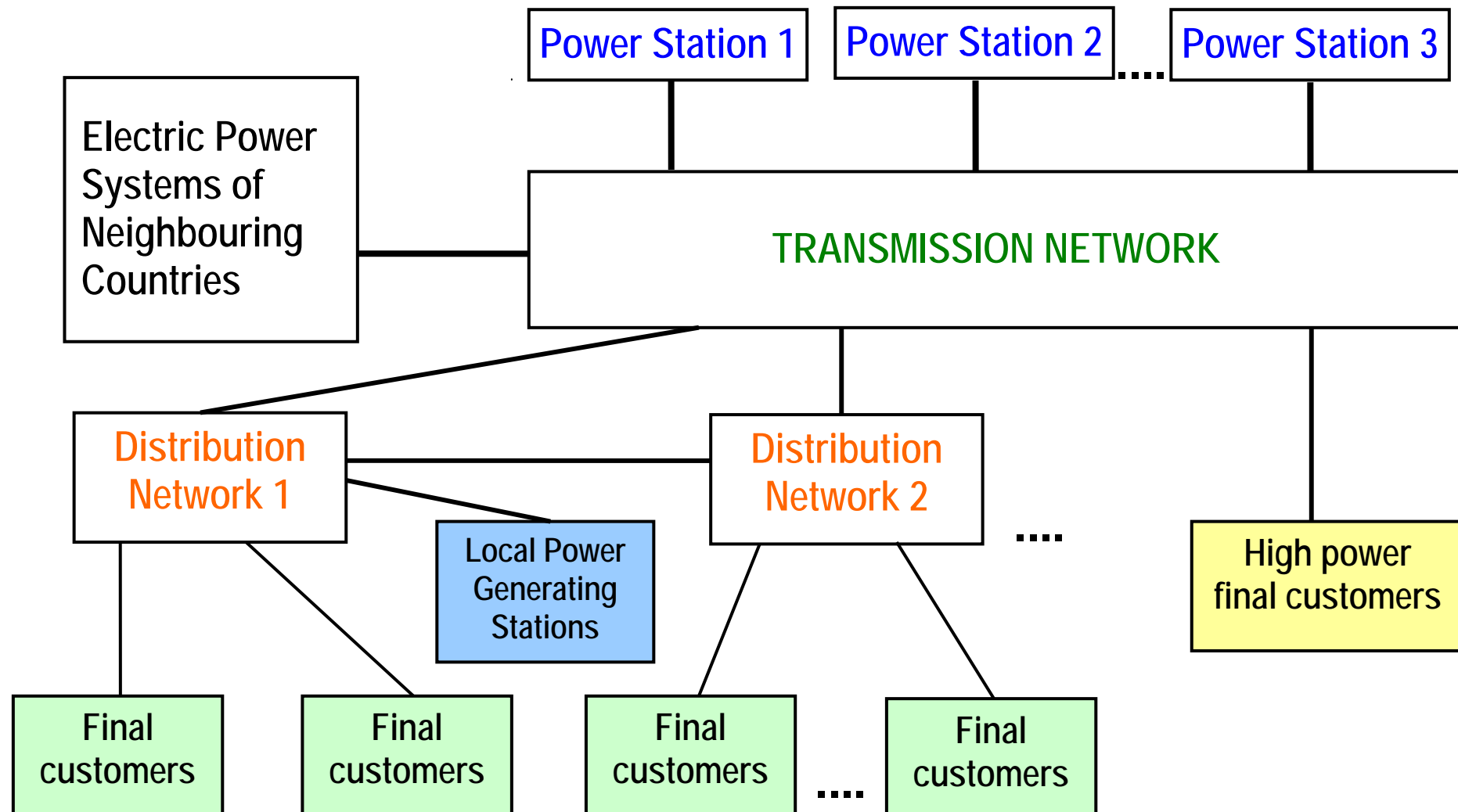

## What it is an Electric Power System (EPS)?

A small part of a transmission network  
(distribution networks in this area are not shown).

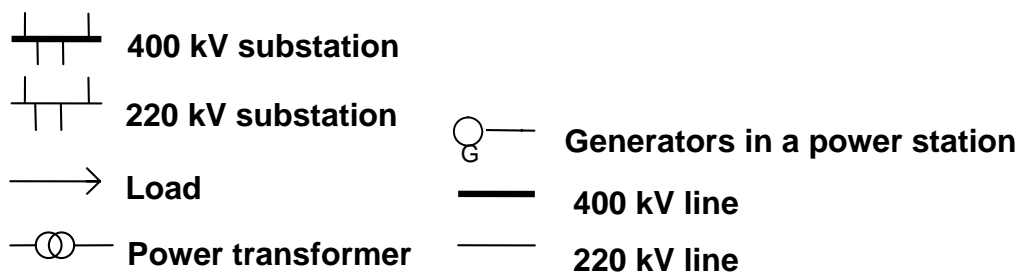
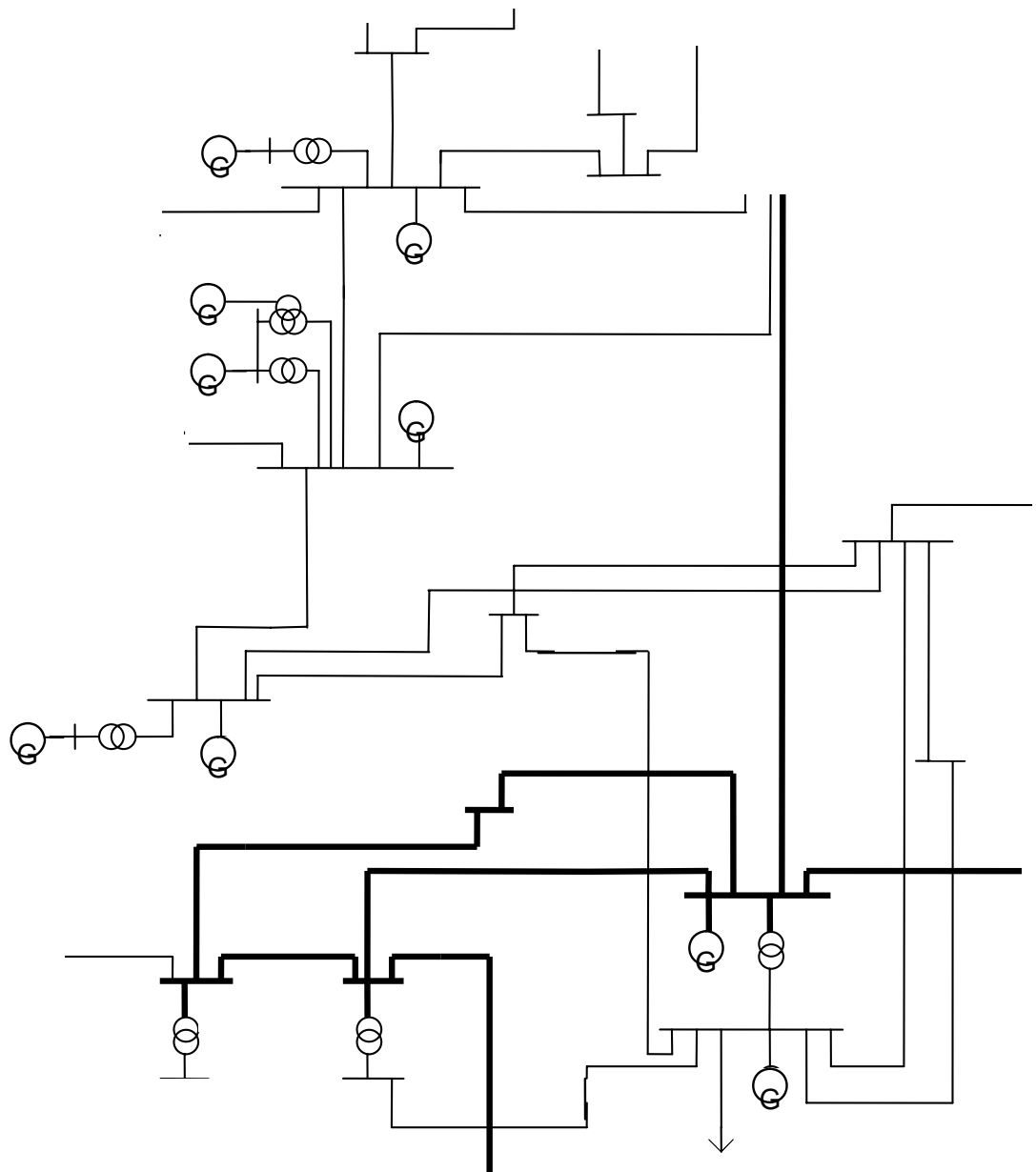

# What it is an Electric Power System (EPS)? – Power stations

## Simplified schematic diagram of a thermal power station

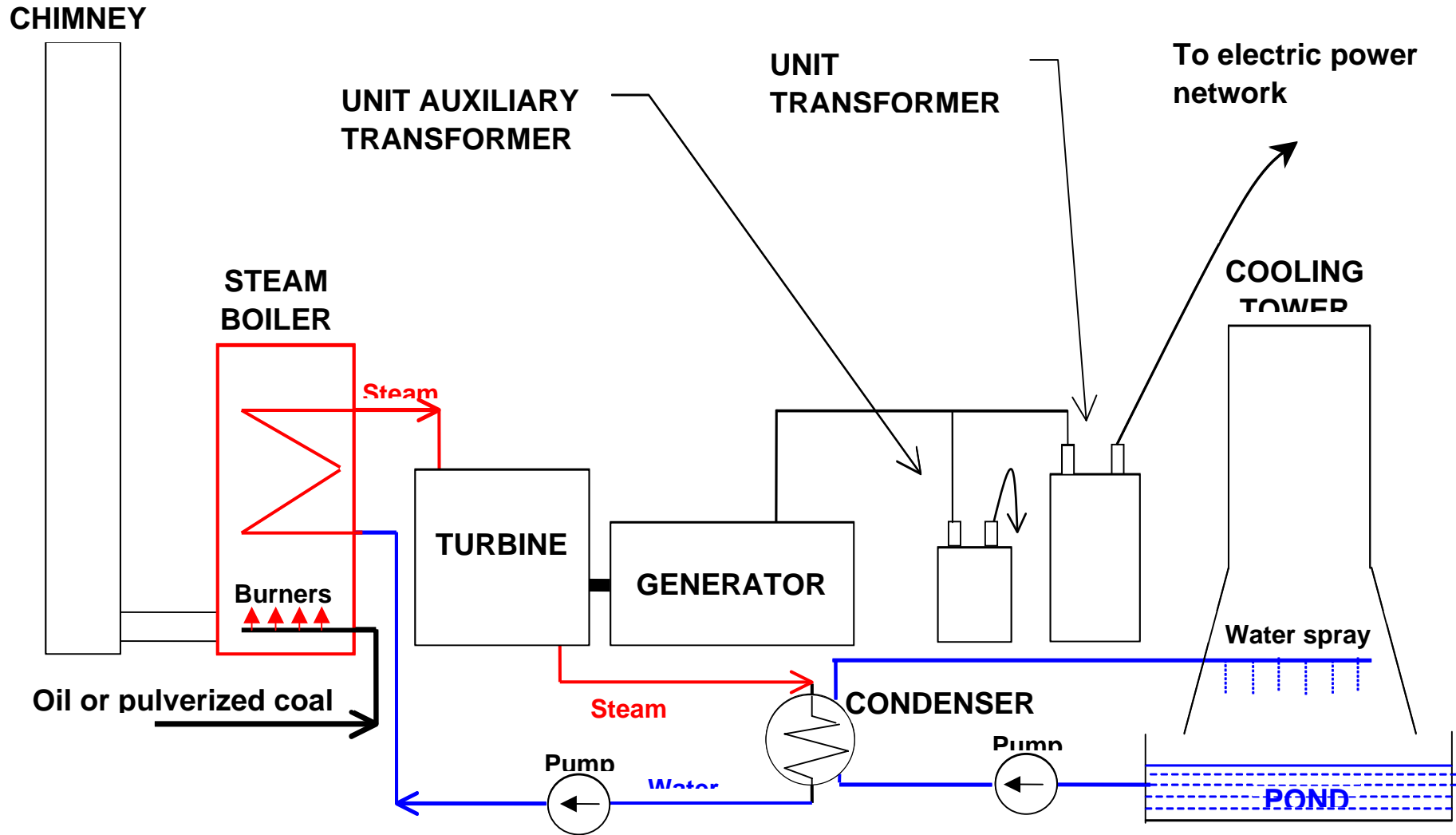

## **What it is an Electric Power System (EPS)? - Substations**

---

Substations form vital nodes of an EPS, which make possible to change a configuration of a transmission or a distribution network in the EPS and voltage transformation.

Electric power substations consist of two essential parts:

1. **Main circuits called also primary circuits**
2. **Auxiliary circuits called also secondary circuits.**

The basic elements that form a main circuit are:

- **circuit breakers,**
- **disconnectors,**
- **power transformers,**
- **busbars.**

## **What it is an Electric Power System (EPS)? - Substations**

---

The secondary circuit can consist of following subsystems:

- 1. Protections (for the detection and the elimination of faults)**
  - a) busbar protection,**
  - b) feeder (line) protection,**
  - c) transformer protection.**
  
- 2. Automation**
  - a) load shedding (frequency control),**
  - b) network splitting (islanding),**
  - c) load restoration,**
  - d) sequential switching,**
  - e) synchronization,**
  - f) tap-changer control (voltage regulation).**

## **What it is an Electric Power System (EPS)? - Substations**

---

### **3. Control/operation**

- a) operating (switch-on line or transformer, switch-off, tap change, etc.),**
- b) bay interlocking,**
- c) substation interlocking.**

### **4. Control/monitoring**

- a) status indications,**
- b) alarms and annunciations,**
- c) measurement/load monitoring (I, U, P, Q, t, f),**
- d) metering (energy measurement),**
- e) reports,**
- f) event recording,**
- g) disturbance recording,**
- h) fault location.**

## **What it is an Electric Power System (EPS)? - Substations**

---

- 5. AC/DC auxiliaries (generation, conversion, transmissions, supply to substation equipment).**
- 6. Fire-fighting (fire detection, fire extinguishing).**
- 7. Air conditioning (required by indoor equipment and/or human requirements).**

**All interconnected power stations and networks of a given EPS must be reliable operated to assure reliable electricity supply to final customers.**

**This real-time operation of an EPS is carried out from control centres in transmission and distribution networks.**

**In currently created free electricity market customer should have right to buy electricity from a free selected power station.**

# What it is an Electric Power System (EPS)? - Switching operations control in a substation

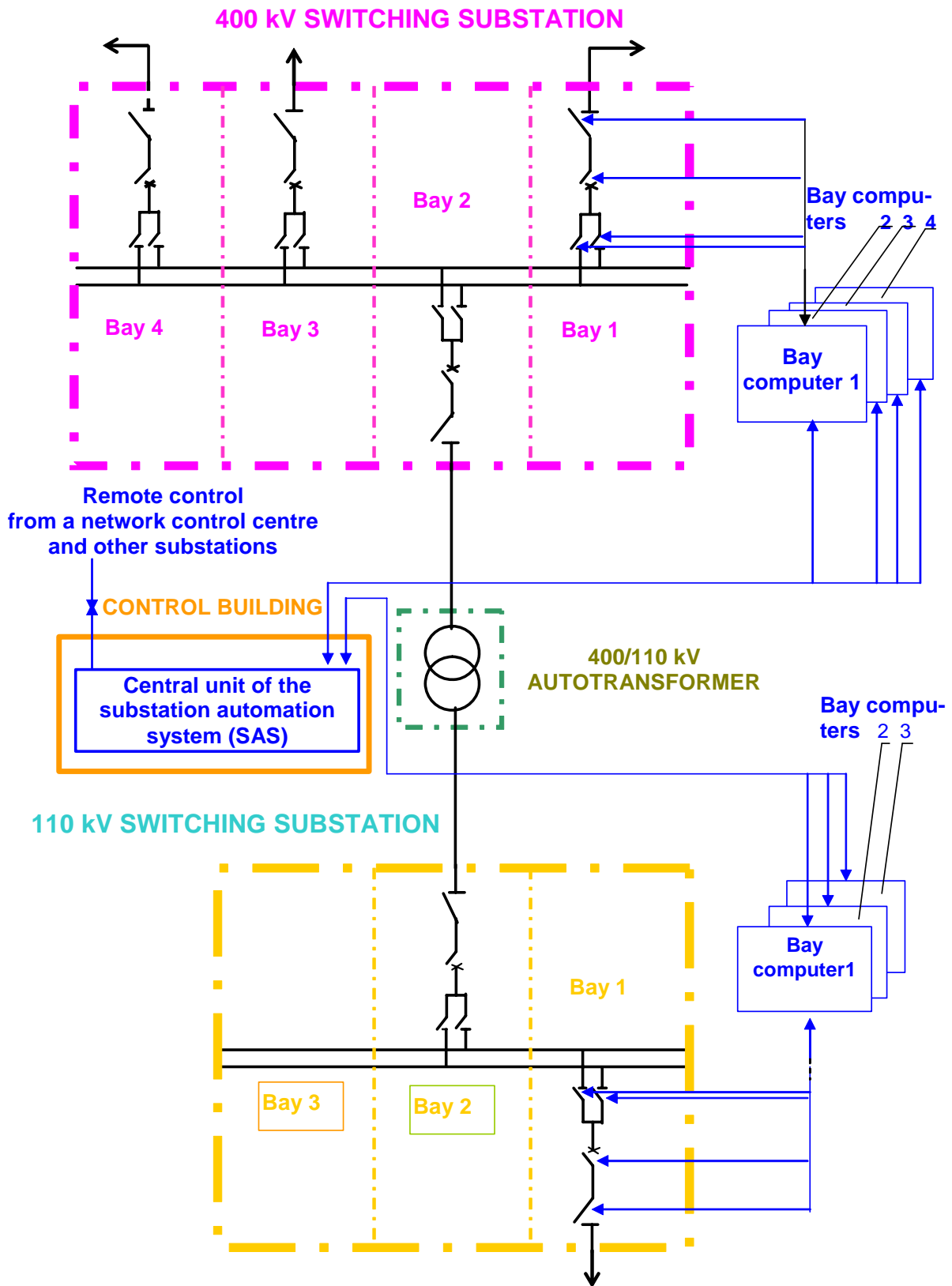

## **What it is an Electric Power System (EPS)? - Telecommunication network**

---

**Telecommunication network of an EPS makes possible:**

- **phone communication**
- **remote measuring**
- **remote control**
- **teleprotection, and**
- **data transmission**

**In the last decade, due to process of computerization of EPSs, an incredible growth of telecommunications demand is observed.**

**A development of computer control and protection systems tends toward creation very large, distributed computer systems, being spread on wide area, of hundred kilometres or more.**

**A concept of time-base is applied to ensure such systems an ability of settling a chronology of events placed in distant objects.**

# What it is an Electric Power System (EPS)? - Telecommunication network

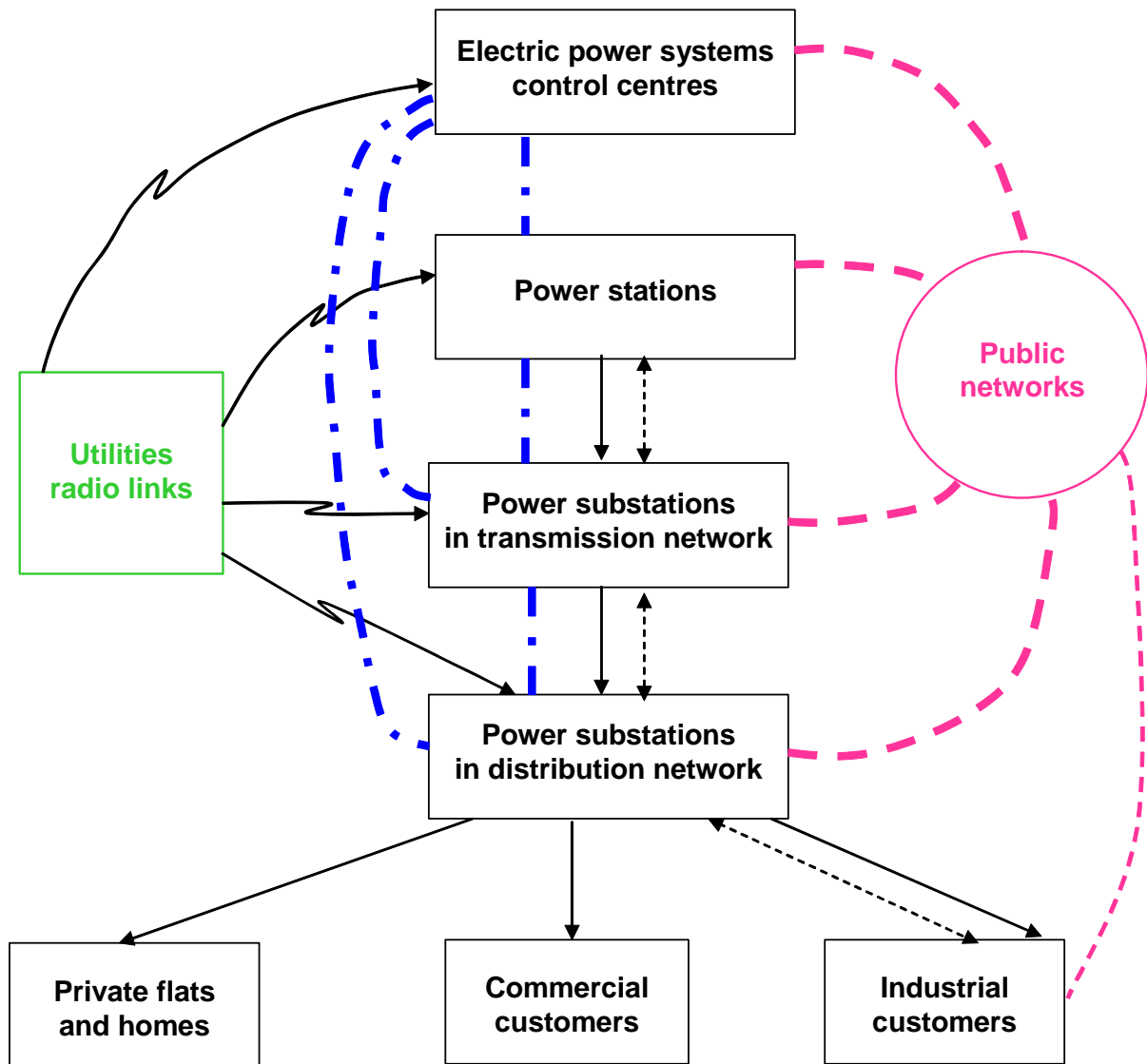

- Energy flow in normal operation of an EPS
- - - - - Energy flow in a failure state of an EPS
- . - . - . Private utilities networks
- - - - - Leased lines from public telecommunication network and connections to Internet
- - - - - Connection to an EPS some big industrial consumers by Internet

# What it is an Electric Power System (EPS)? - EPS protection, operation and control

## The concept of an electric power system control

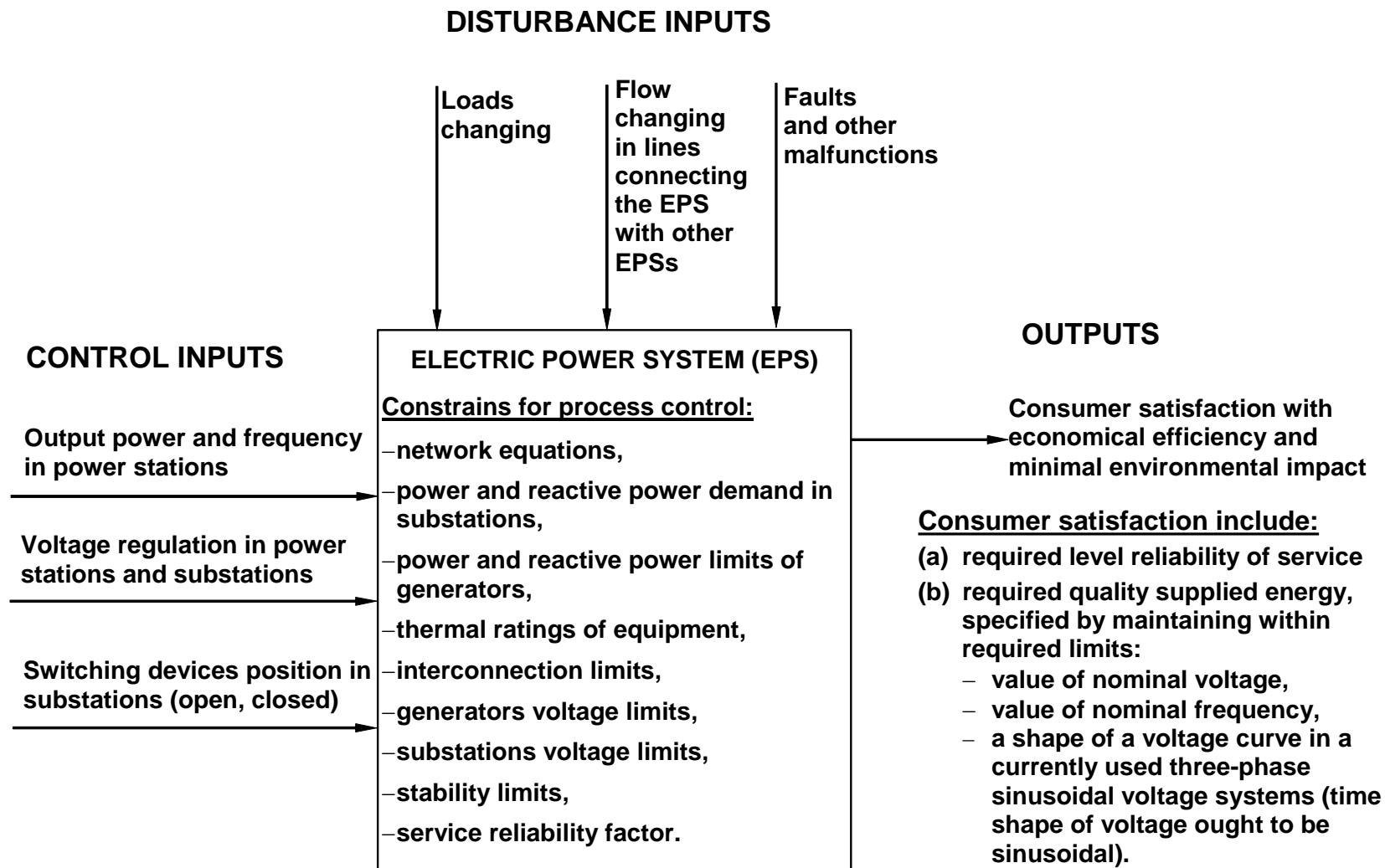

## **What it is an Electric Power System (EPS)? - EPS protection, operation and control**

---

**All generators in power stations connected to an EPS are synchronised and they must be synchronised before they are connected to an EPS.**

**At present there is no possibility for accumulation of large amount of electrical energy disposable without delay. Power generated in an EPS must be maintained in constant equilibrium with power consumed (demanded).**

**If power consumed increases in an EPS the EPS frequency will decrease. The frequency deviation is initially influenced by the kinetic energy of all rotating generating units and motors connected to the EPS.**

**Regulating units must then perform rapid automatic action to re-establish balance between power demanded and generated.**

## **What it is an Electric Power System (EPS)? - EPS protection, operation and control**

---

**Normally (e. g. in Poland) all commercial power stations are connected to the national transmission network and the action is carried out by automatic systems of frequency control and economic power dispatch from the National Dispatching Centre via the telecommunication network.**

**The following unique physical features of EPSs cause that safe operation and ensuring continuity of electricity supply to customers is very difficult:**

- Dispatched power must be equal to the power demand in every moment.**
- Differently than in any other infrastructure it is practically impossible to plan the way of electricity flow in power grid.**

## **What it is an Electric Power System (EPS)? - EPS protection, operation and control**

---

- **In EPSs all lines, transformers, generators, etc. are protected by protection devices that operate within tens milliseconds, fraction of a second or – very rarely - a few seconds at the most.**

**If an EPS is not carefully planned and operated it is very easy to trigger a cascading effect that leads to a great power system failure.**

**The Northeast Blackout of 1965 was initiated by protective relay (set too low) that triggered cascading development the outage. About 30 million people and 207 km<sup>2</sup> in Ontario, Canada, and United States were without electricity for up to thirteen hours.**

## **Current situation in education curricula**

---

**The automation of present day electric power systems is more and more based not only on hardware but also on software solutions.**

**Because of very complex nature of electric power systems, design of the software-based systems is not possible without participation of electric power systems experts, starting from the specification and analysis of requirements phase and ending with the phase of systems validation.**

**The situation - described in the quotation from “Electra” Journal - contribute probably to the fact that, at least in Polish Universities, in Electrical Engineering Faculties curricula courses on computing are limited to functionality of computer systems and networks and to knowledge needed for operation of these systems and networks, and do not contain courses connected with ensuring their quality features like dependability and security.**

**And certainly these curricula contribute to the situation in electric power sector, and this is a positive feedback.**

## Current situation in education curricula

---

**The Smart Grids European Technology Platform for Electricity Networks of the Future began its work in 2005. Its aim is to formulate and promote a vision for the development of Europe's electricity networks looking towards 2020 and beyond.**

**It is a new concept for electricity networks across Europe using as far as it will be possible all achievements in information technology that - similarly like free electricity market – will completely change our imagination on power grid operation**

**([http://ec.europa.eu/research/energy/pdf/smartgrids\\_en.pdf](http://ec.europa.eu/research/energy/pdf/smartgrids_en.pdf) ).**

# Proposal of information technology courses for Electrical Engineering Faculties

---

## 1. Fundamentals of Computer Science

- Computer systems main concepts and components.
- Hardware architecture and components.
- Application versus system software.
- Overview and examples of operating systems.
- Programming fundamentals.
- Overview of programming languages, object-oriented programming.
- Database features, functions, and architecture.
- Real-time and embedded systems.
- Fault tolerance.
- History of computing (the world before 1946, history of computer hardware, software and networking).
- Intellectual property (copyrights, patents, and trade secrets, software piracy, transnational issues).

# Proposal of information technology courses for Electrical Engineering Faculties

---

## 2. Dependability of Computer-Based Systems

- Main concepts.
- The principles of safety hazard and risk identification and assessment.
- Implications of software complexity, historical examples of software risk.
- System safety assessment.
- Overview of safety analysis techniques, selecting appropriate techniques.
- ALARP concept.
- International Standard IEC 61508.
- Safety Case concept.
- The principles of security hazard and risk analysis.
- Computer crime, history and examples of computer crime.
- System security, physical security, communications security, and logical system security.
- International standard BS ISO/IEC 17799.
- Man-machine interface (human factors).

# Proposal of information technology courses for Electrical Engineering Faculties

---

## 3. Requirements Engineering

- Overview of software engineering (system and software life-cycle, software requirements, software design, testing and maintenance, software engineering tools and methods, software quality).
- Principles and problems of requirements specification.
- Specification techniques (natural language techniques, formal specification).
- Formal methods concepts, formal specification languages and formal verification.
- Software requirements tools (requirements modelling, traceability).
- Safety analysis and its role in requirements engineering.
- Examples of safety analysis techniques (Fault Tree, FMEA).
- Security analysis in the phase of requirements specification.
- Current requirements standards.
- Examples and case studies.

# Proposal of information technology courses for Electrical Engineering Faculties

---

## 4. Computer Networks and Distributed Systems

- Basic concepts.
- Overview of OSI reference model.
- Local Area Networks.
- Wide Area Networks.
- Overview of network issues in International Standards IEC 60870, IEC 61334, and IEC 61850.

## Proposal of information technology courses for Electrical Engineering Faculties

---

**The suggested courses are necessary to efficiently design software-based systems applied in electric power systems but they would also increase the attraction of electrical engineering faculties, which are declining because, as it is given in one of CIGRE publications, due to old-fashioned curricula student interests are shifting to computers, semiconductors, and communication.**

**It has been assumed that the proposed set of courses would include both lectures and laboratories co-ordinated with the lectures. The lectures should emphasise fundamentals while laboratories current technology and know-how.**

## Proposal of information technology courses for Electrical Engineering Faculties

---

**On the basis of these courses, possibly supplemented by a certain number of more detailed courses, a specialization in the field of computer systems and networks design and operation might be set up in these departments in order to train engineers who might take over the functions of requirement engineers in this sector and co-operate with software engineers in all further phases of the process of a computer system or network design.**

## **Proposal of information technology courses for Electrical Engineering Faculties**

---

**They could also take over the supervision over the operation, maintenance and development of systems and networks applied in electric power systems that is considered one of the most critical national infrastructures.**

**It is justified view that application of a system approach would have a catalytic influence on acquired quality of teaching. Development of conceptual models of a problem in the process of system and software requirements specification is fundamental to the requirements analysis. The models encompass a target control system, controlled object, operator of the control system, maintenance the system during operation and widely understood influence of environment.**

**For this reason in some publications requirements engineering is even considered as fundamentally an activity of systems engineering rather than one that is specific to software engineering.**

## Proposal of information technology courses for Electrical Engineering Faculties

---

**Therefore one can expect that independently of the improvements quality of computer systems and networks used in electric power sector as well as increase the attraction of electrical engineering faculties, introduction of the above mentioned courses to education curricula would have a catalytic influence on acquired quality of teaching and modern, system view of engineering design.**